

Kite Aerial Photography

David Hunt
kaper3@earthlink.net
www.kaper.kiteaerialphotography.net

Copyright 2002

Kite Aerial Photography Camera Cradle

Materials

1-FujiFilm QuickSnap Disposable Camera
(w/o Flash)

4-Tongue Depressors ~6" long
(Craft stores may call these Craft
Sticks)

7/16" Wooden Dowel (7.5")

1-Plastic Screw-On Soft Drink Cap

2-#32 Rubber Bands

1-#8 X 3/4" Bolt

1-#8 X 2" Bolt

1-#8 Nut

1-#8 Wing Nut

4-Small Screw Eyes

1-Small Washer

Foam Core Poster Board, 3/16" Thick

Wire Coat Hanger

3" - 1/4" aluminum tubing

3" - 5/32" aluminum tubing

2 - Small Split Rings (Key Rings)

Heavy Button Thread

30 feet of Twine
(Braided Nylon or Dacron would be
better if you can find it)

Small Nail or Brad

Silly Puttys

Contact Cement

Tools

Ruler

Hobby Knife

Needle Nose Pliers

Wire Cutters

Drill with 1/16", 3/32" & 3/16" bits

Hammer

Hack Saw

Kite Aerial Photography Camera Cradle

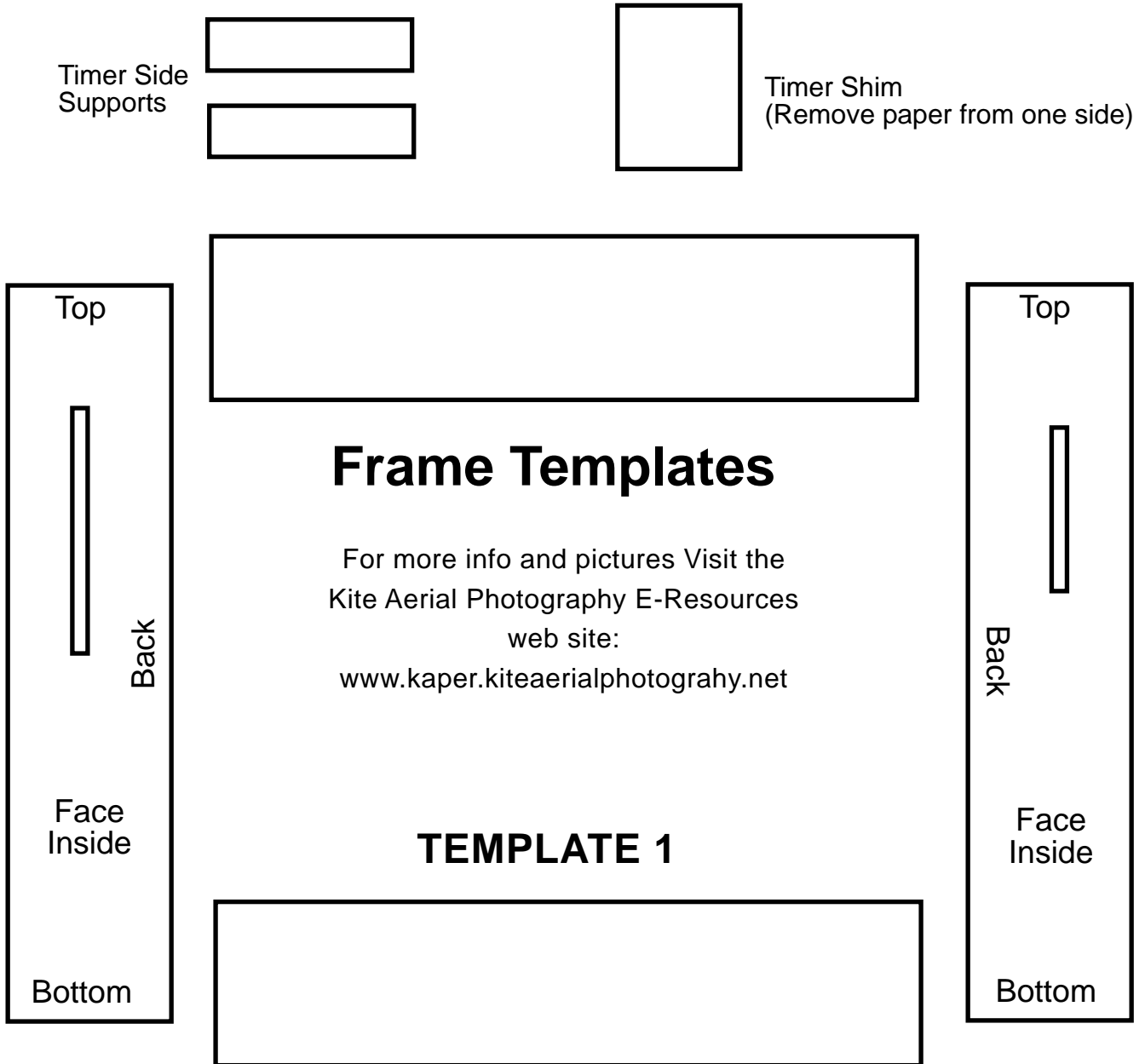

1. The **Templates** will work with the FujiFilm “QuickSnap Outdoor” disposable camera. Start by cutting a 1inch strip from the 20 inch edge of a foam core poster board. All the pieces above can be cut from one 20 inch strip. Notice that the slots in the side pieces are not exactly in the center of the width. During assembly make certain that both edges labeled “Back” face the same direction as well as the edges labeled “Top”. The slots are positioned to line up with the shutter button on the camera. Also note that the paper must be trimmed from one side of the “Timer Shim” piece.

Kite Aerial Photography Camera Cradle

2. Drill a 3/32" hole through opposite sides of the plastic soft drink cap. (**Figure 1**)

3. Cut the cap in half with the hack saw. Cut along a line that is perpendicular to the line between the two holes. (**Figure 1**)

4. Glue the four camera frame pieces together (**Figure 2**). Take care that the top, bottom, and back edges of the two side pieces are oriented in the same direction. Refer to Template 1.

5. Glue the two halves of the bottle cap on each side of the short slot (**Figure 3**). The open side of the cap facing away from frame. The holes should be perpendicular to the slot. (**Figure 7** may help also)

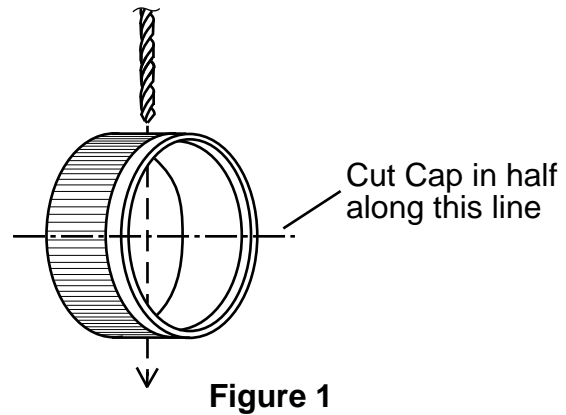
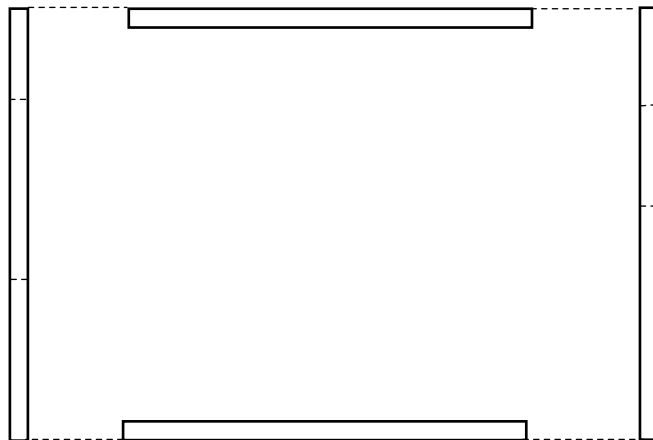
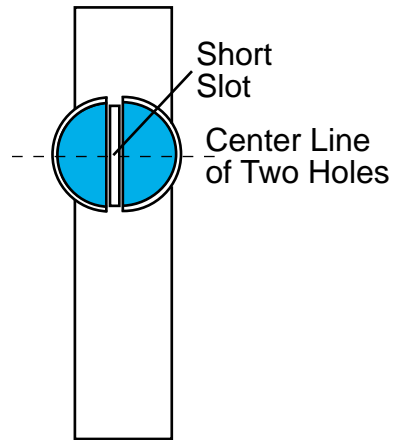

Figure 1



Front View

Figure 2



Side View

Figure 3

Kite Aerial Photography Camera Cradle

Viscous Timer

Figure 4

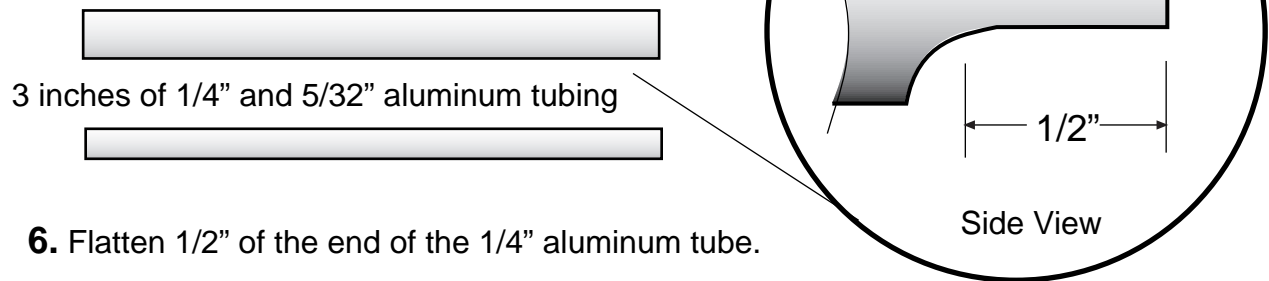

6. Flatten 1/2" of the end of the 1/4" aluminum tube.
7. Press Silly Puttys into the 1/4" tube. Use the 5/32" tube to pack the Silly Puttys to the bottom 3 or 4 times during the process.
8. Fill the 1/4" tube to within 1/4" of the open end.
9. Force the 5/32" tube into the Silly Puttys as far as you can. There should be about 3/4" of the smaller tube protruding.
10. Drill a 3/16" hole in the center of the flattened end so the timer can be attached to the cradle with a #8 nut and bolt.
11. Drive a nail or brad through the small tube.

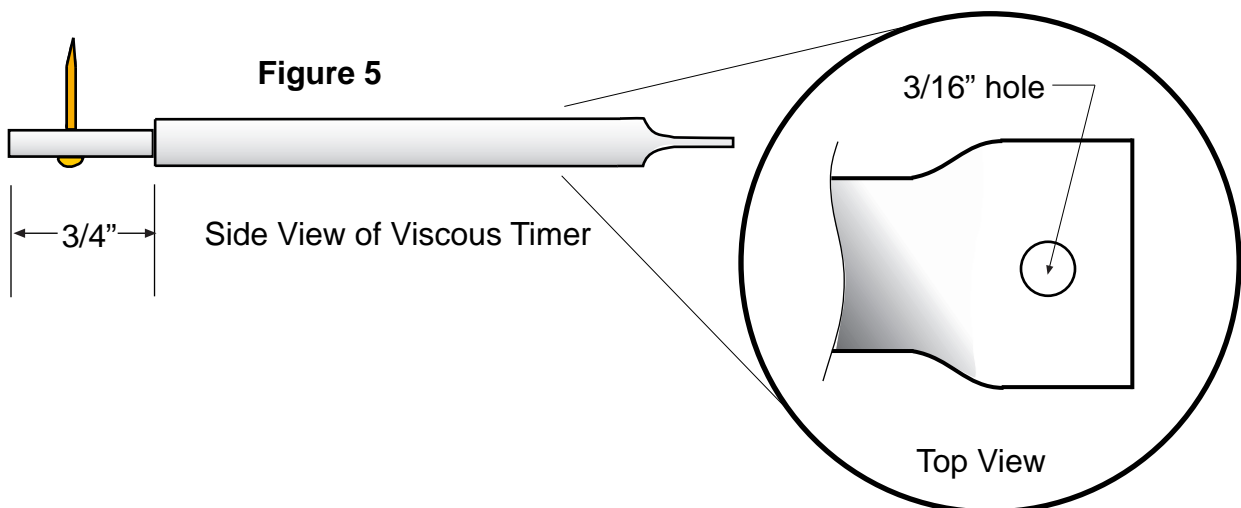

Kite Aerial Photography Camera Cradle

12. Position the Viscous Timer on top of the camera frame with the smaller tube hanging over the side. Slide the timer shim under the flattened end of the Viscous timer and mark the position of the shim and then glue shim in place, paper side up. (**Figure 6**)

13. Reposition the Viscous Timer on the frame and mark the center of the hole. Drill a 3/16" hole through the shim and frame at the center mark. (**Figure 6**)

14. Attach the Viscous Timer to the camera frame with a 3/4" - #8 nut and bolt.

15. Glue the Timer Side Supports to frame on each side of the Viscous Timer.

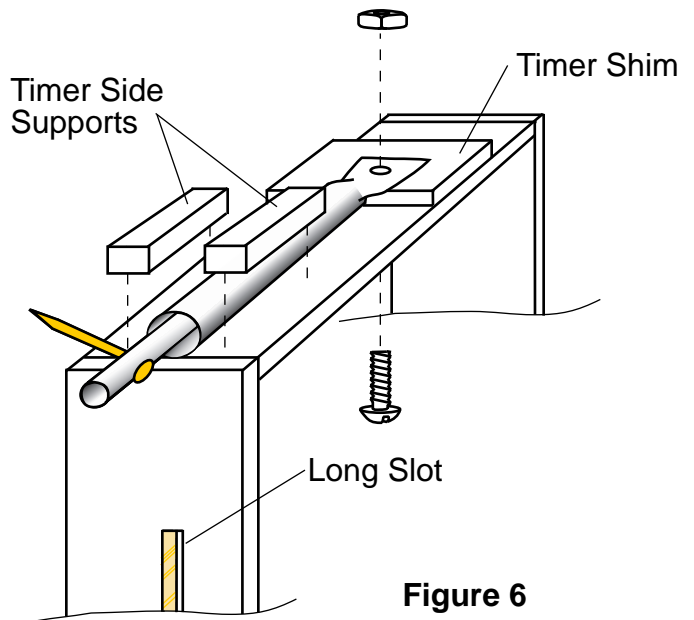
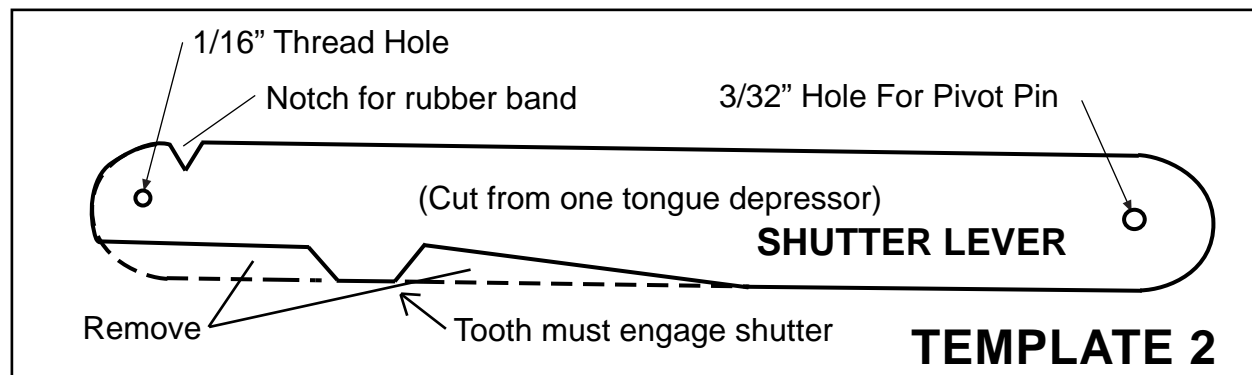

Figure 6



16. Use **Template 2** to mark tongue depressor to be used for the shutter lever.

17. Drill the 3/32" hole first then mount the shutter lever to the frame using a 3" length of coat hanger wire. Double check that the tooth marked on the shutter lever is aligned properly with the shutter button on the disposable camera before cutting out the toothed area. Also make sure that the notch for the rubber band is on the portion of the shutter lever that extends past the frame.

18. Remove the shutter lever from the frame and finish cutting out the tooth and the notch and drilling the hole to attach the thread. The notch

19. When the shutter lever is finished remount it to the camera frame with the same 3" length of coat hanger wire. Bend both ends to prevent the wire from falling out (**Figure 7**).

20. Glue a tongue depressor across the back of the camera frame. An equal amount should hang over each side and the bottom edge of the tongue depressor should be 5/8" from the bottom edge of the frame (**Figure 7**).

Kite Aerial Photography Camera Cradle

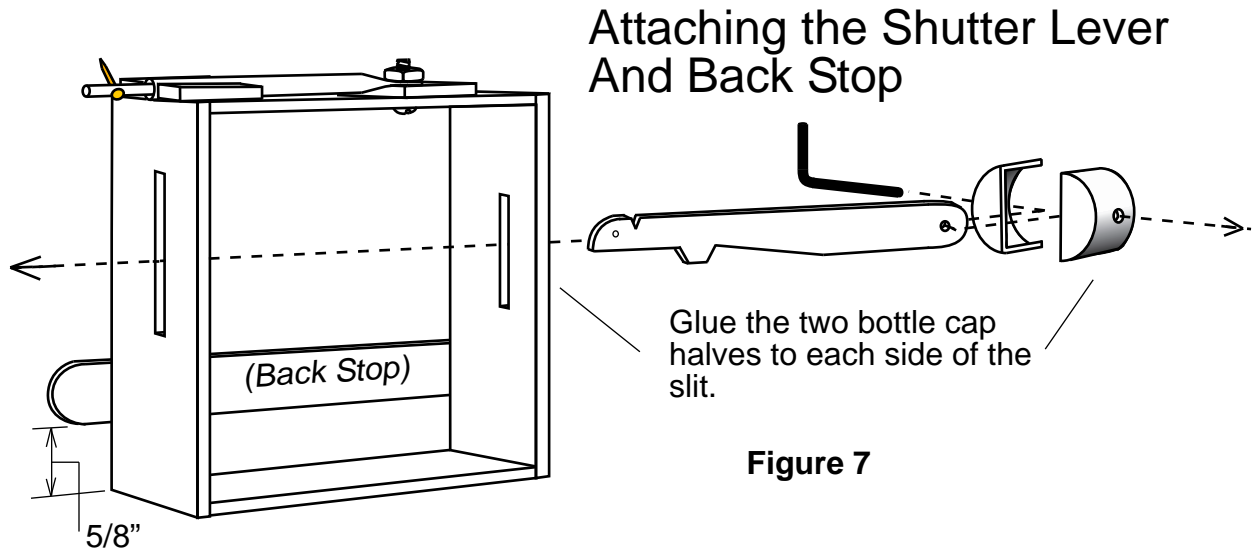

21. Tie a knot in the middle of a #32 rubber band (**Figure 8**). This is to shorten the rubber band and provide enough force for the shutter lever to depress the shutter button.

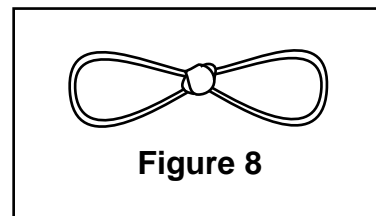

22. Use the loop on one side of the knot (the other side will hang free). Slip it over the end of the back stop that extends out from the side with the long slot and also over the end of the shutter lever. Use the notch to keep the rubber band from slipping off the end of the shutter lever. Be sure that the cement holding the back stop has had sufficient time to dry.

23. Set the camera in the frame with the lens facing away from the back stop, and hold it in place by using a #32 rubber band looped over each end of the back stop and across the front of the camera. Be sure that the rubber band does not obscure the camera lens (**Figure 9**).

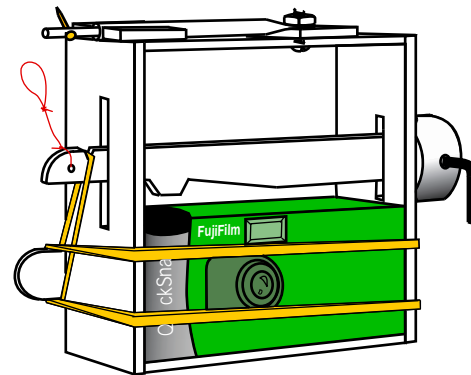

Note: The shutter lever would normally be depressing the shutter button if the thread was not connected to the timer.

24. Cut a 6" length of button thread.

25. Tie a 1" loop in one end.

26. Tie the other end to the shutter lever through the small hole next to the notch. Make certain that the shutter lever is held

at least 1/2" above the camera's shutter button when the thread is looped over the timer nail and the timer is set.

Kite Aerial Photography Camera Cradle

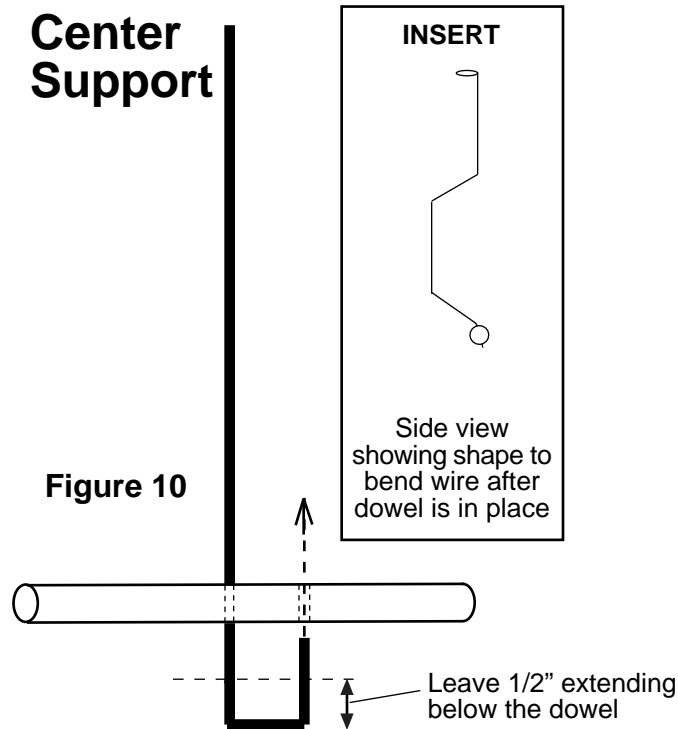

Center Support

Figure 10

Picavet Cross

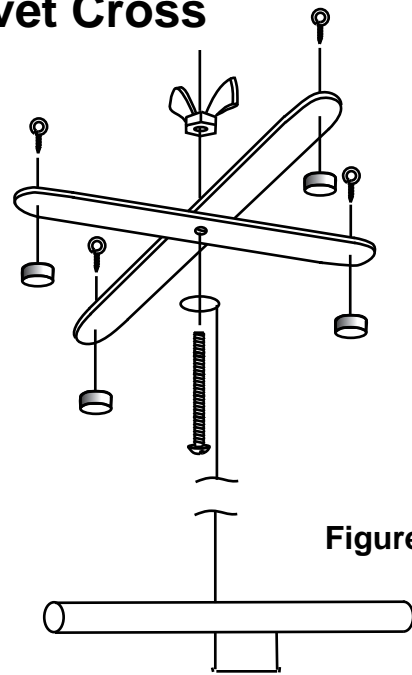

Figure 11

27. Starting with a 7.5" length of 7/16" wood dowel. Cut four 3/8" lengths from one end leaving about 6" of dowel.

28. Drill a 3/32" hole through the 6" piece of dowel at the midpoint. Drill another 3/32" hole 1" to the side of the center hole.

29. Start with 12" of straightened coat hanger wire. Bend a square bottomed "U" as shown in **Figure 10**. Insert the long portion of the wire through the center dowel hole, the short side through the adjacent hole.

30. Bend a loop in the top end just big enough for a #8 bolt. Bend the loop 90° so that it faces down toward the dowel (see Insert).

31. Bend the shape into the midsection of the wire as shown in the insert above. The purpose of this shape is to make it easier to change the camera's angle of downward tilt.

32. Glue two tongue depressors together forming a cross with arms of equal length (**Figure 11**).

33. Glue the four 3/8" lengths of 7/16" dowel to the ends of each arm.

34. Drill a 3/16" hole through the center of the cross. Attach the center support to the cross using a 1" #8 bolt and wing nut (**Figure 11**).

35. Drill pilot holes and screw small screw eyes through arms into the dowels. The faces of each eye should be parallel with each other and face the end of one arm (**Figure 12**).

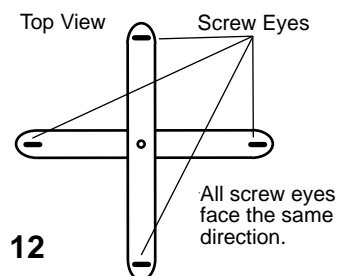
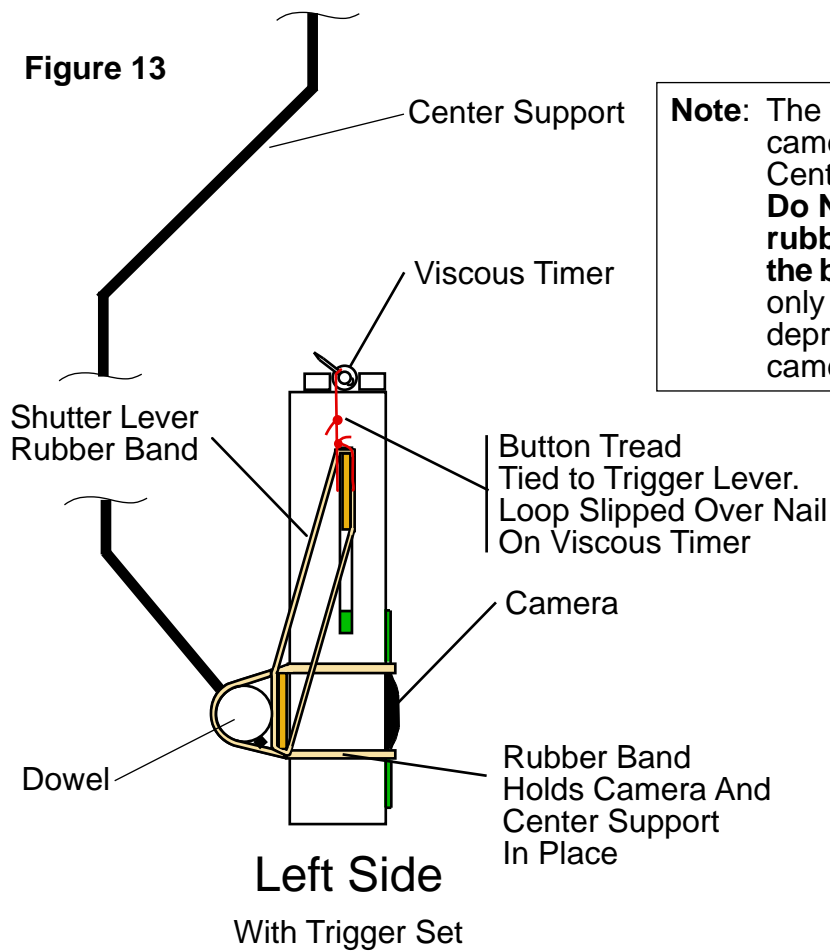
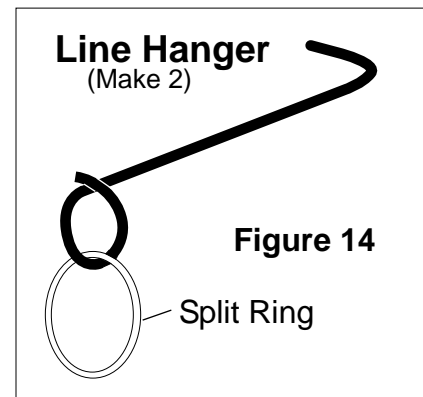

Figure 12

Kite Aerial Photography Camera Cradle



Note: The rubber band that holds the camera in place also holds the Center Support
Do Not loop the Shutter Lever rubber band over the dowel at the bottom of the Center Support, only over the end of the tongue depressor glued to the back of the camera frame.



36. Attach the camera frame to the Center Support dowel by using the same rubber band that holds the camera in the frame (**Figure 13**). Just slip both ends of the dowel under the rubber band that is looped over the tongue depressor used as a back stop.

DO NOT LOOP THE SHUTTER RUBBER BAND OVER THE DOWEL. The shutter rubber band should only be looped over the shutter lever and the back stop tongue depressor.

37. Cut two 6" lengths of coat hanger wire to make the line hangers needed to attach the camera cradle to the kite line.

38. Form each length of wire into the shape shown in **Figure 14**. Start by firmly grasping one end of the wire with needle-nosed pliers and grasping the other end in your hand and forming a circle around the jaws of the pliers.

39. Finish forming the line hanger into the shape shown in **Figure 14**.

40. Slip a split ring into the circle of each line hanger. Use the pliers to close the gap in the line hanger circle to prevent the split rings from slipping out.

Kite Aerial Photography Camera Cradle

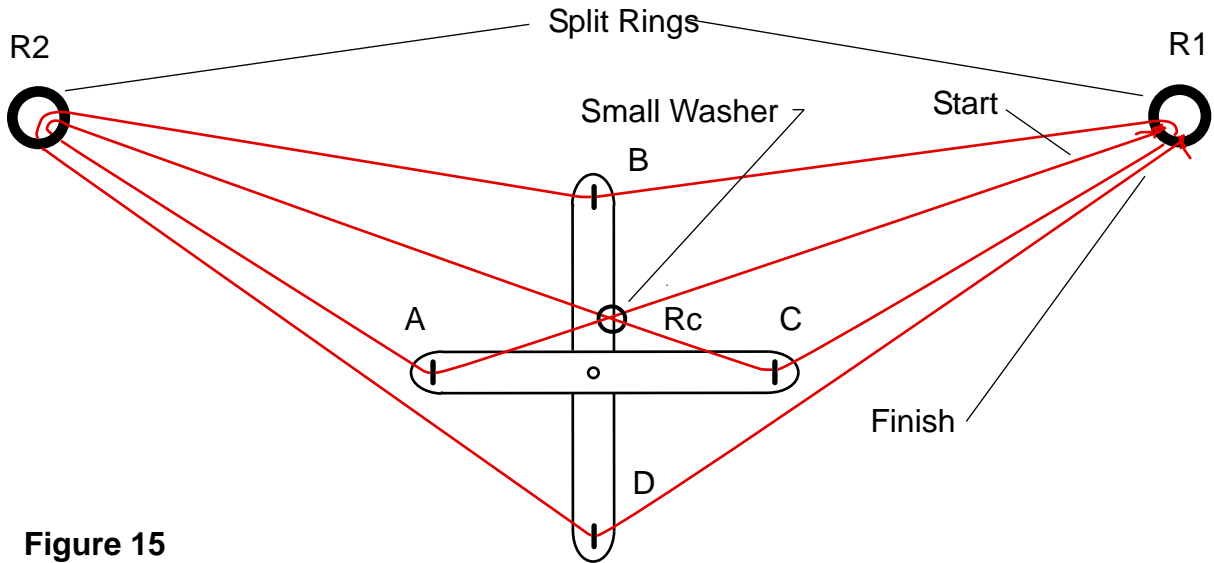

Figure 15

41. Cut a 30 foot length of kite line.
42. Get an assistant to hold a line hanger in each hand.
43. Tie one end of the kite line to one of the rings. Then follow the path indicated in **Figure 15** above. The opposite end of the kite line should end up tied to the same ring that the beginning of the line is tied.
44. Here is a step by step description of the path to thread the kite line using the labels in **Figure 15**.

Tie one end to R1. Thread the other end according to this sequence;
Rc-A-R2-Rc-C-R1-B-R2-D-tie to R1

The purpose of the small washer labeled Rc is to keep the Picavet Cross from turning around its center.

The Camera Cradle is complete!!!

Now lets see how to use it.

USING THE CAMERA CRADLE

Launch your kite and get it to a height where there are good steady winds. I normally let out about 100 feet of line.

Have an assistant hold the kite line. Attach the first Line Hanger about 10 feet up the line from your assistant (**Figure 16**). Make sure that the split ring is toward the kite. Make 7 or more turns of the line

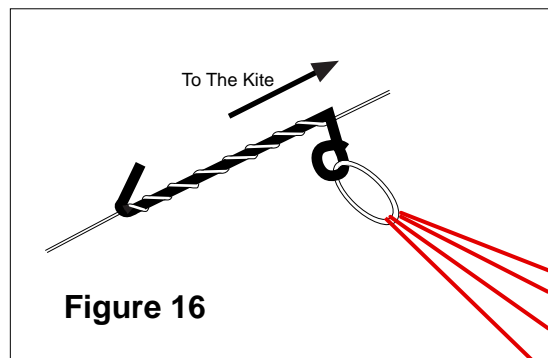

Attach the second Line Hanger about 5 feet further up the line from the first Hanger. Orient the camera in the general direction you wish to take pictures.

Kite Aerial Photography Camera Cradle

To set the timer, turn the inner tube of the Viscous Timer until the nail points straight back (**Figure 17**). Lift the Shutter Lever and slip the loop of thread over the Nail. Turn the inner tube clockwise to 2 minutes or more of time.

(You will have to experimentally determine how much to turn the timer to produce the delay times needed. Each timer will be slightly different)

Wind the camera to the next picture.

CAUTION!- DO NOT wind the camera while the shutter is depressed. If you do the camera's shutter will trip as soon as you have wound to the next frame.

After the timer is set, let out more line to get the camera cradle to the height you desire (**Figure 18**).

To take the next aerial photograph you do not have to wind your kite line in. Instead with an assistant holding end of the kite line, grab the kite line and walk toward the kite, hand-over-hand, until you come to the camera cradle (**Figure 19**).

Aim the camera in a new direction if you wish, reset the timer. This time you will only need about a minute, because you will be able to get the kite back up faster than the first time. After the timer is set **don't forget to advance the film** to the next picture. Now walk back toward your assistant still holding the line. The kite will slowly rise and take the camera cradle with it.

CAUTION!

DO NOT just let go of the line when the timer is set and the film is advanced. In strong winds the camera cradle will rocket into the air causing damage to the cradle and / or tangling of the lines on the Picavet Cross. You **MUST** walk back, hand-over-hand, toward your assistant.

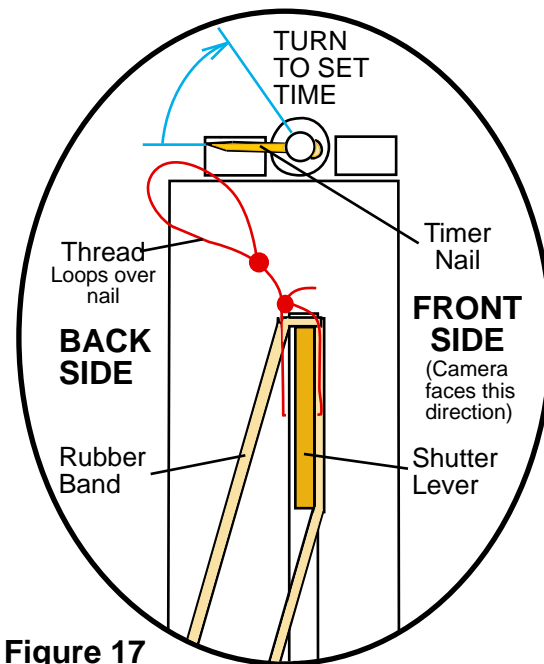

Figure 17

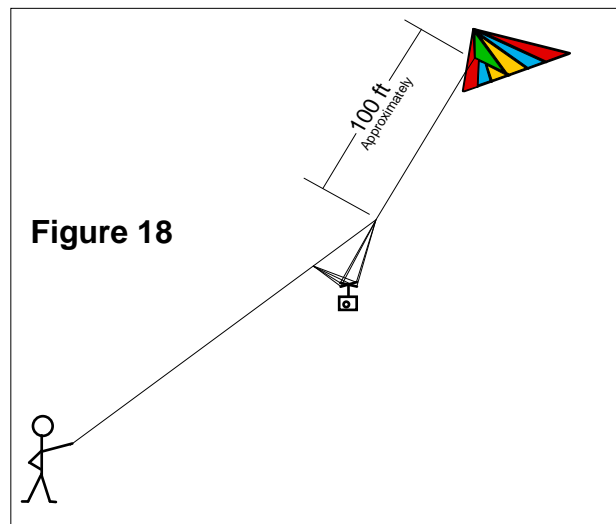

Figure 18

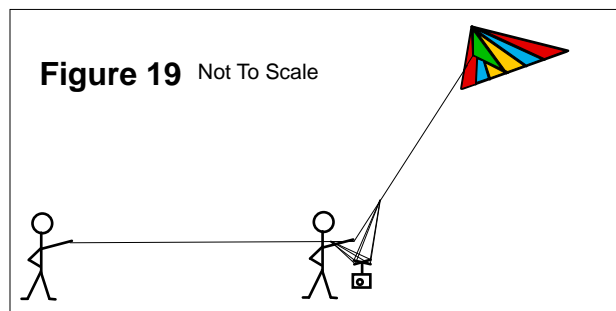

Figure 19 Not To Scale